

## SECTION H

### STEERING

<u>Section</u>	<u>Description</u>	<u>Page</u>
H.1.	General description	3.
H.2.	Steering wheel	3.
H.3.	Inner column	3.
H.4.	Outer column	5.
H.5.	Steering unit lock stops	5.
H.6.	Steering unit	5.
H.7.	Steering arms	15.

ILLUSTRATIONS

<u>Fig. No.</u>	<u>Description</u>	<u>Page</u>
1.	Layout of steering & front suspension	4.
2.	Steering column	6.
3.	Impact clamp adjustment	8.
4.	Outer column bush locations	8.
5.	Cutaway view of an outer column bush	8.
6.	Limitation of steering lock	8.
7.	Steering unit dimensions	10.
8.	Steering unit components	11.
9.	Removing steering unit clamp	13.
10.	Removing rubber mounting	13.
11.	Tie rod coupling details	13.
12.	'O' ring in the retaining ring	14.
13.	Measuring pinion end float	14.
14.	Measuring cap nut head/pinion housing clearance	14.
15.	Rotating the pinion	14.

H.1. - GENERAL DESCRIPTION

The steering gear is of the direct acting rack-and-pinion type, there being no separate steering linkage. On the ends of the steering unit rack are adjustable tie-rods to which are attached the ball-joints, these in their turn being directly attached to the steering arms. The steering arms are bolted to the vertical link.

Maintenance

Lubrication of the lower swivel bearings (trunnions) is most important to maintain accurate steering; (see Section 'C' - Front Suspension). The steering unit should be lubricated as given in Section 'O' (Lubrication and Maintenance).

H.2. - STEERING WHEELTo Remove

1. Set the wheels in the straight-ahead position.
2. Prise out the central button (horn push) from the hub of the steering wheel.
3. Using a suitable socket, or box spanner, release the securing nut and pull off the steering wheel. A straight upward pull is all that is required as the wheel is splined to the inner column.

To Replace

1. Replacing the steering wheel is a direct reversal of the removal procedure, noting that no force is necessary to locate the wheel on the splines of the inner column.

H.3. - INNER COLUMNTo Remove

1. The inner column is in two parts and can only be removed in these two parts, unless the inner and outer columns are removed as an assembly.
2. From the lower end of the outer steering column, remove the impact clamp. Using a steady pull, pull the upper column with steering wheel attached, from its location.
3. Release the pinch bolt retaining the lower inner column to the steering unit pinion coupling, then push the column up into the outer column. With the aid of a suitable rod, continue pushing the lower inner column up the outer column until it can be removed from the interior of the car.

To Replace

1. Replacing the inner columns is a reversal of the removal procedure. Check that there is clearance between the underside of the steering wheel hub and the outer steering wheel column.

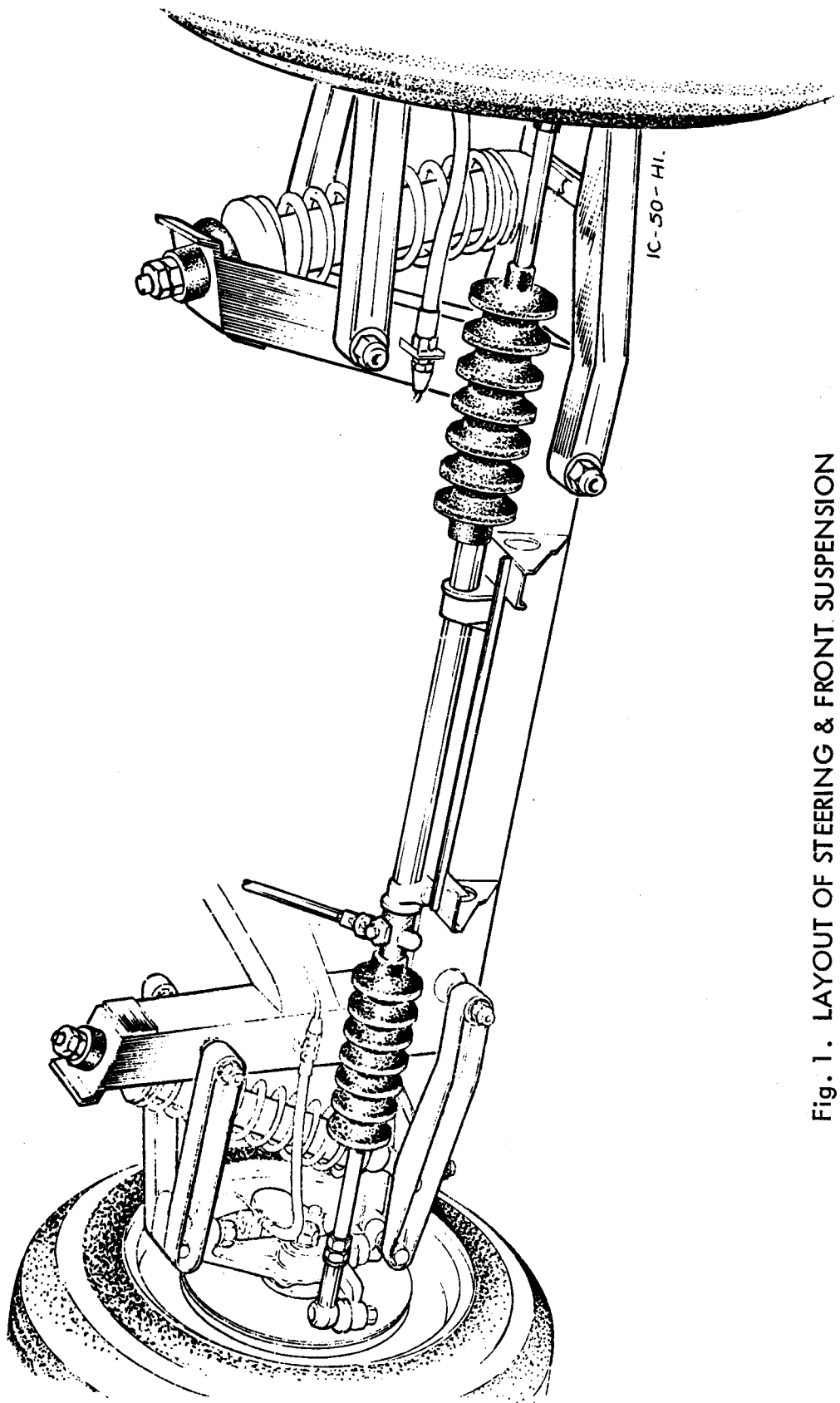

Fig. 1. LAYOUT OF STEERING & FRONT SUSPENSION

2. The 'flats' on the lower column and the 'cut-out' in the upper column should, of course, be in line with each other to ensure the impact clamp is fitted correctly. Ensure the impact clamp is fully tightened, with the steering column in the midway (up and down) position. If the clamp is tightened with the column in the fully down position, it will not be able to collapse in the event of an impact.

#### H.4. - OUTER COLUMN

##### To Remove

1. Disconnect the battery.
2. Mark the position of both the headlamps dipswitch and the direction indicator switch cables in their connectors, then release cables.
3. Release pinch bolt retaining the lower inner column to the steering unit coupling.
4. From below the fascia panel, release the nuts securing the upper column clamp. The nuts securing the lower column clamp are accessible from the foot well. Remove assembly from car. Remove inner column, (Section 'H.3') and bushes.

##### To Replace

1. Fit the new nylon bushes to their locations in the outer column, so that the securing lugs engage in the holes of the outer column. The metal reinforcement of each bush is towards the lower end of the column. Replace inner column.
2. Replace column assembly into its location and loosely attach the retaining clamps.
3. Tighten steering unit pinion to inner column coupling pinch bolt after ensuring clearance between hub of steering wheel and outer column. Fully tighten the two retaining clamps.
4. Replace the switch cables in their connectors, finally reconnect the battery.

#### H.5. - STEERING UNIT LOCK STOPS

Limitation of the steering lock (Fig.6) is controlled by the locknut contacting the rack tube. Thus dimension '3' of Fig.7 is particularly important. Providing that this dimension is accurate and the steering unit is centrally mounted on the chassis, correct steering locks should result. See also Section 'C' under 'Steering Geometry'.

#### H.6. - STEERING UNIT

##### To Remove

1. Remove the front wheels (see Section 'G').
2. Remove the nuts and free the ball-joint ends of the tie-rods from their respective steering arms.

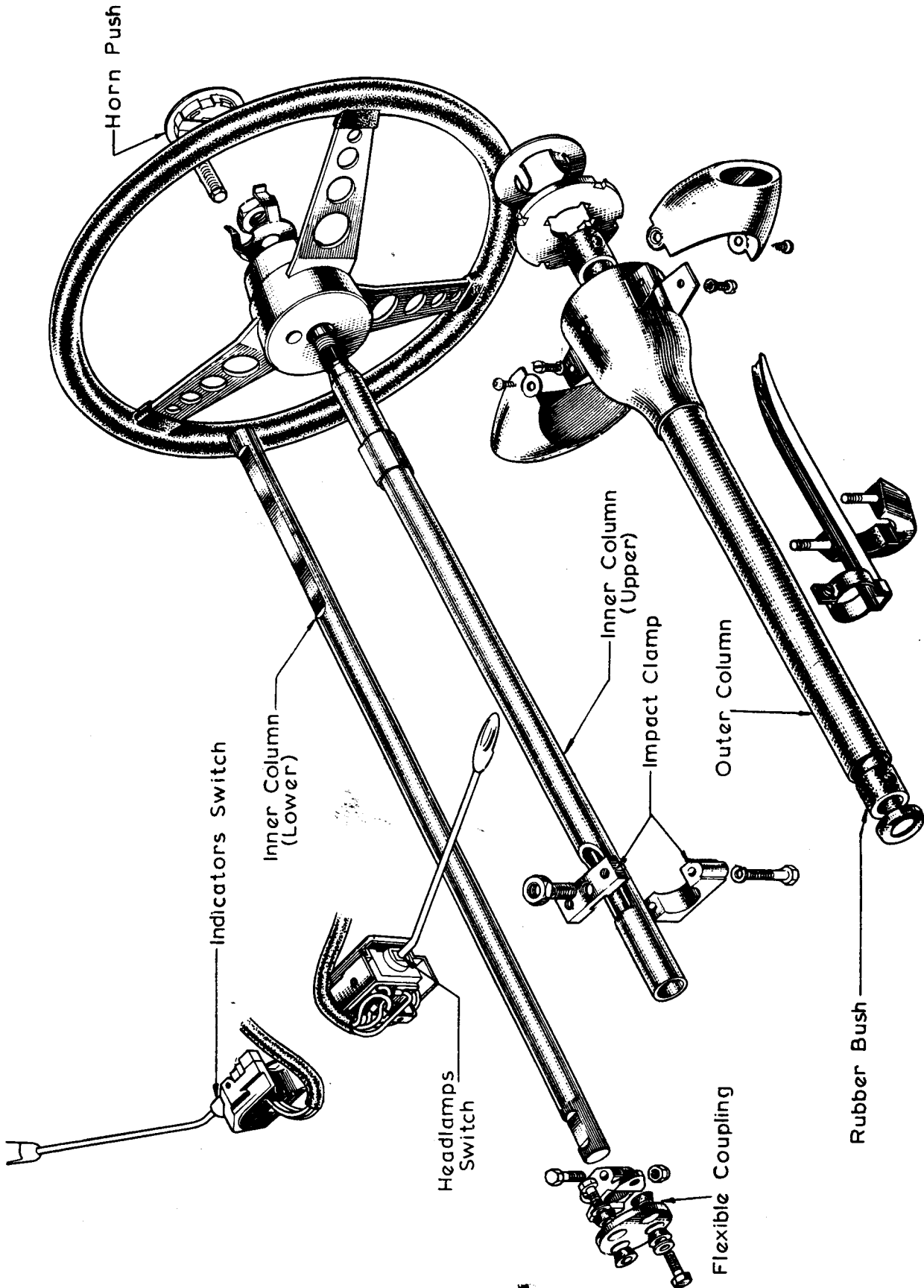

Fig. 2. STEERING COLUMN

3. Release the pinch bolt securing the inner steering column to the steering unit pinion coupling.
4. Remove the nuts with their washers securing the steering unit clamps to the chassis. Note that these clamps also secure the unit shims (to ensure correct unit height), and that the clamp adjacent to the pinion also retains the earth strap.
5. Move the steering unit forward to disengage the coupling from the inner steering column and remove unit from car.

#### To Dismantle

1. Release the clips securing the ends of the bellows and slide both bellows towards the outer ends. Slacken the locknuts and unscrew both outer tie rod/ball-joint assemblies from the rack. Withdraw the spring from each end of the rack.
2. Release the tabwasher, unscrew the sleeve nut and remove the tabwasher, shims and cup. Slacken the locknuts and unscrew the outer ball joint assemblies from the tie rods.
3. Remove the locknuts, rubber bellows, clips and cup nut from each outer tie-rod.
4. Remove the locknuts from the ends of the rack. Unscrew the cap and remove the shims, spring and pressure pad from the housing.
5. Remove the circlip and withdraw the pinion assembly, taking care not to lose the dowel peg. Remove the retaining ring, shims, bush and thrust washer. Detach the rubber 'O' ring from the annular groove in the retaining ring.
6. Withdraw the rack from the tube and remove the thrust washer and bush from the pinion housing.

#### Inspection

Clean and examine all components for wear and damage, renewing parts as required. It is particularly important to check the ball end of the tie-rod for 'necking'. This 'necking' if evident, can be recognised as a groove running around the circumference of the ball-to-rod waist. If 'necking' has occurred (or if there is any doubt) RENEW the tie-rod. If necessary, renew the bush in the end of the rack tube, by drifting out the old bush and pressing in a new one.

#### To Assemble

1. Insert the rack into the tube and place the bush and thrust washer into the pinion housing.
2. Adjust the pinion end float as follows:-
  - a. Assemble the thrust washer, bush and retaining ring to the pinion. Insert the

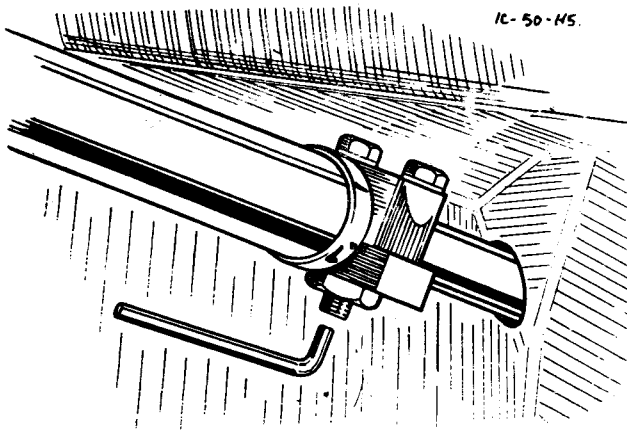

Fig. 3. IMPACT CLAMP ADJUSTMENT

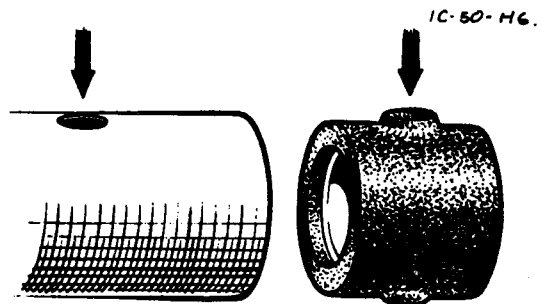

Fig. 4. OUTER COLUMN BUSH LOCATIONS



Fig. 5. CUTAWAY VIEW OF AN OUTER COLUMN BUSH

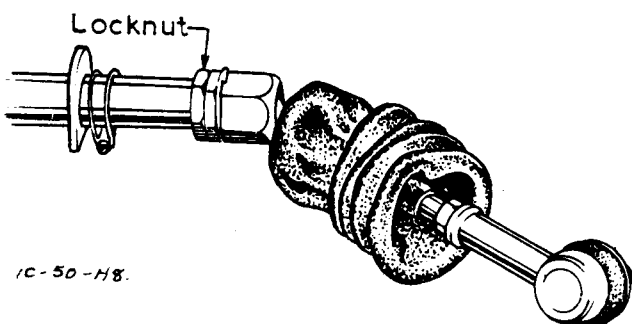

Fig. 6. LIMITATION OF STEERING LOCK



- assembly into the pinion housing and secure the pinion with the circlip.
- b. Mount a dial gauge on the tube as shown in Fig.13. Push the pinion down to its limit and zero the dial gauge. Lift the shaft until the retaining ring contacts the circlip and note the dial reading. This represents the total pinion shaft end float. Remove the circlip and withdraw the pinion shaft assembly. Remove the retaining ring and fit a new rubber 'O' ring.
  - c. Make up a shim pack to give minimum end float consistent with free rotation of the pinion shaft. Shims are available in .004 in. (.102 mm.) and .010 in. (.254 mm.) thickness.
  - d. Assemble the shim pack and retainer ring to the pinion. Re-insert the assembly into the housing and finally secure it by fitting the dowel and circlip.
3. Adjust the pinion pressure pad as follows:-
- a. Fit the plunger and cap nut to the pinion housing. Tighten the nut to eliminate all end float and, using feeler gauges, measure the clearance between the nut and housing as shown on Fig.14. Remove the cap nut and plunger.
  - b. Make up a shim pack equal to the cap nut to housing clearance, plus .004 in. (.102 mm.)
  - c. Pack the unit with grease and assemble the cap nut, shim pack, spring and plunger to the housing and tighten the cap nut.
  - d. When the nut is correctly adjusted, a force of 2 lb. (.91 kg.) is required to rotate the pinion at a radius of 8 in. (20.3 cm.) (see Fig.15). Check and re-adjust the unit, if necessary, by adding or subtracting shims from beneath the cap nut.

#### Assembling the Tie-Rod

1. Slide the cup nut over the tie-rod and insert the cup into the cup nut.
2. Position the lock tab over the sleeve nut and screw this fully into the cup nut. With the cup nut held in a vice, move the tie-rod axially to determine the approximate shim pack thickness required. Remove the assembly from the vice and remove sleeve nut.
3. Prepare a shim pack in excess of the estimated ball movement and insert this in the cup nut behind the nut.

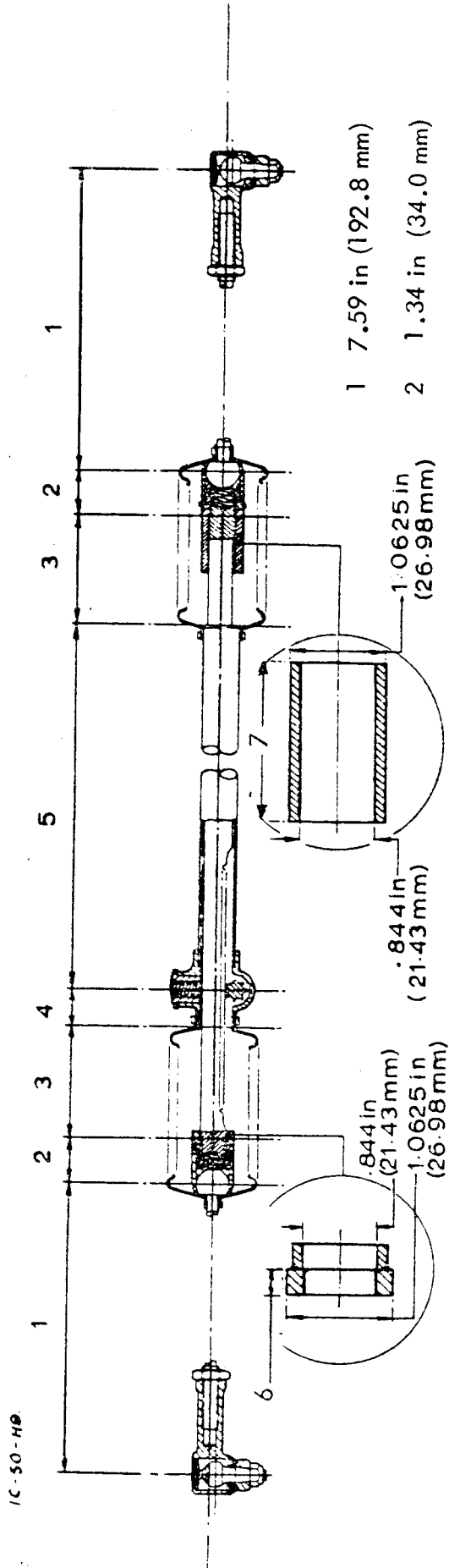

- |   |                          |
|---|--------------------------|
| 1 | 7.59 in (192.8 mm)       |
| 2 | 1.34 in (34.0 mm)        |
| 3 | 3.38 in (85.85 mm)       |
| 4 | 1.03 in (26.2 mm)        |
| 5 | 17.03 in (432.6 mm)      |
| 6 | S1/2/3 0.28 in (7.1 mm)  |
|   | S4 0.53 in (13.5 mm)     |
| 7 | S1/2/3 1.75 in (44.5 mm) |
|   | S4 2.00 in (50.8 mm)     |

Fig. 7 STEERING UNIT DIMENSIONS

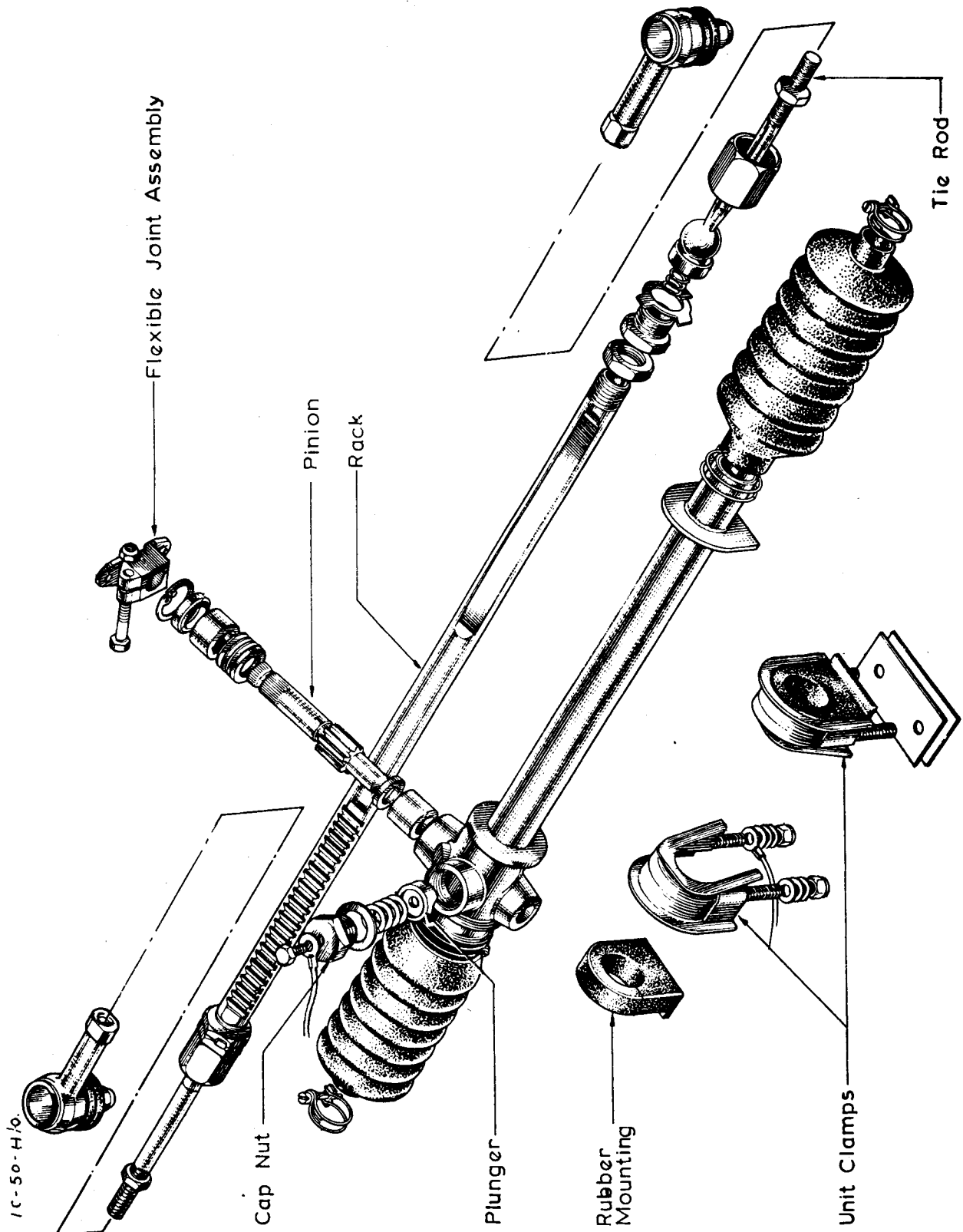

Fig. 8. STEERING UNIT COMPONENTS

4. Screw the sleeve nut with lock tab fully into the cup nut.
5. Using feeler gauges, measure the gap between the sleeve nut flange, lock tab and cup nut face. This dimension, plus .002 in. (.05 mm.) is the amount by which the trial shim pack must be reduced to give the correct ball end movement.
6. Dismantle the ball joint and re-assemble it with the correct shim pack taking care to avoid sudden tightening of the ball joint.
7. Screw the locknuts on to the end of the steering rack.
  
8. Insert the spring into the end of the rack and screw the ball joint assembly as far as possible up to locknut.
9. Push the bellows on to the tie-rods.
10. Fit the locknuts and outer tie-rod ends to the tie-rods screwing them on exactly 25 turns, then secure locknuts.
11. Test adjustment by applying a load of 8 lbs. (3.629 kg.) at the outer end of the tie-rod, when the tie-rod should articulate freely. If necessary, adjust the shim pack until correct operation is obtained. Shims are obtainable in .002 in. (.05 mm.) and .010 in. (.254 mm.) thickness.
12. When adjustment is correct, lock the assembly by bending the lock nut over the sleeve nut and cup nut.
13. Repack the bellows with grease ( $\frac{1}{2}$  oz. of Shell Retinax 'A', or similar) and secure them in position with clips.

#### To Replace

1. Check the shim height required for the steering unit. This is marked on the unit mounting pads of the chassis and must be strictly adhered to, otherwise incorrect steering geometry could occur (i.e. 140 denotes that 3 off .040 in. (1.016 mm.) and 1 off .020 in. (.508 mm.) shims are required. Note that figures may differ from each side necessitating different thickness shim packs.
2. Fit assembly into its location with the hubs in the straight-ahead position. Engage the coupling with the inner steering column.
3. Fit the clamps with their rubber mountings over the steering unit, ensuring that the bolts pass through the shims BEFORE entering their mounting holes in the chassis. Replace earth strap, washers and nuts.

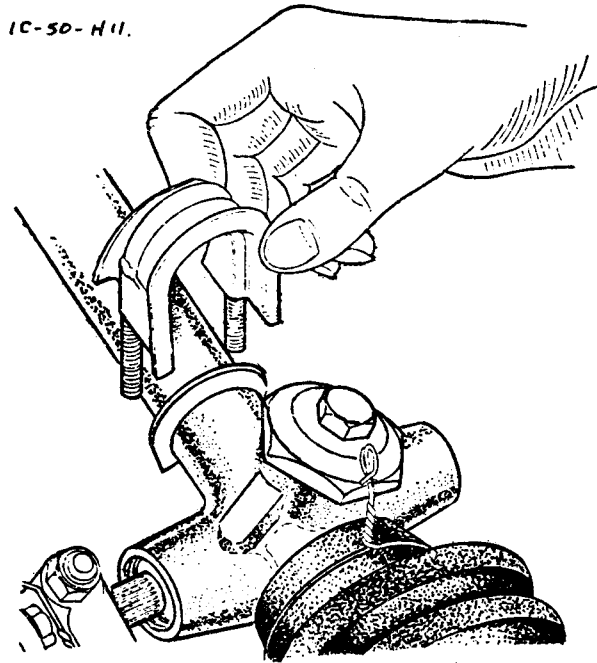

Fig. 9. REMOVING STEERING UNIT CLAMP

1C-50-H13.

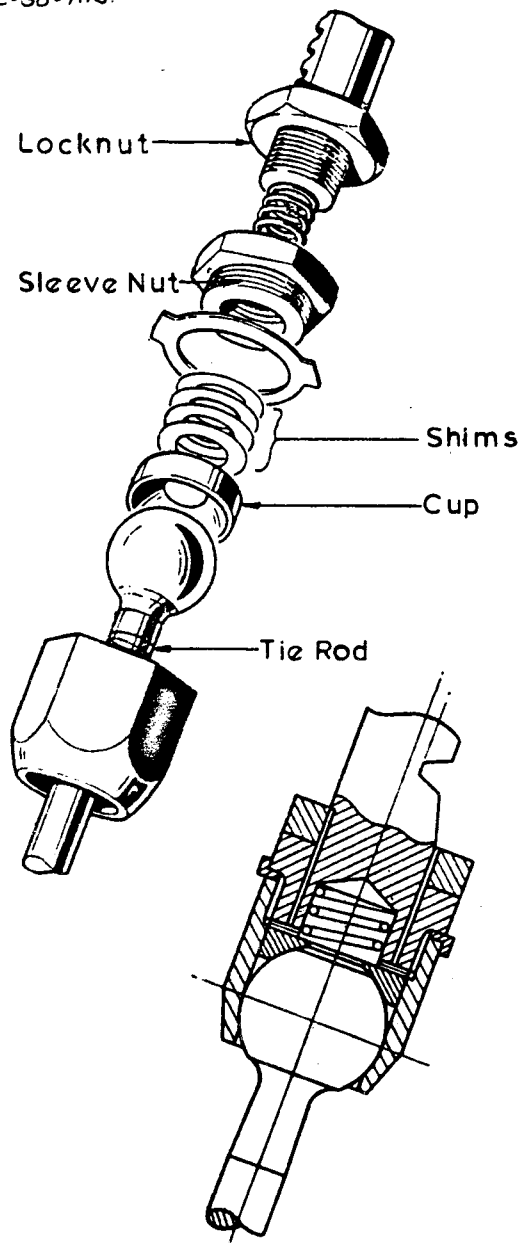

Fig. 11. TIE ROD COUPLING DETAILS

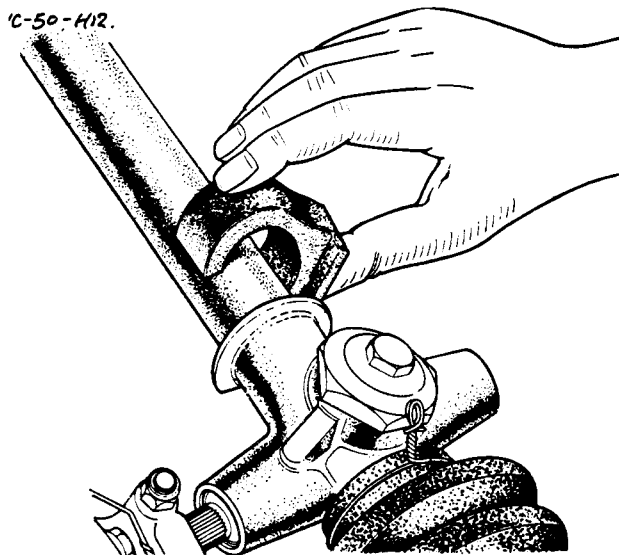

Fig. 10. REMOVING RUBBER MOUNTING

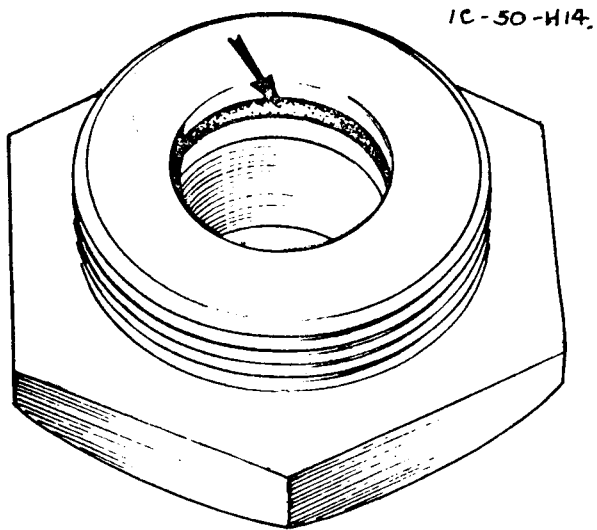

Fig. 12. 'O' RING IN THE RETAINING RING

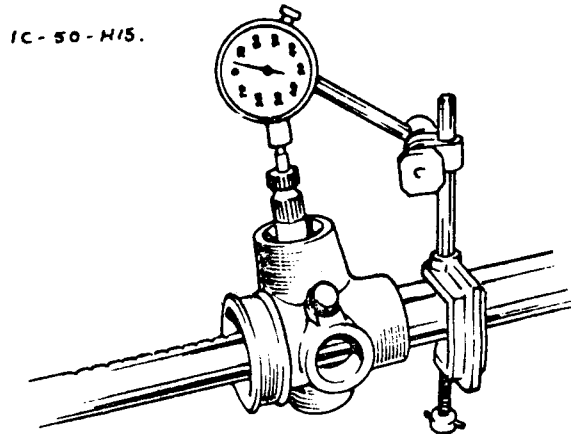

Fig. 13. MEASURING PINION END FLOAT

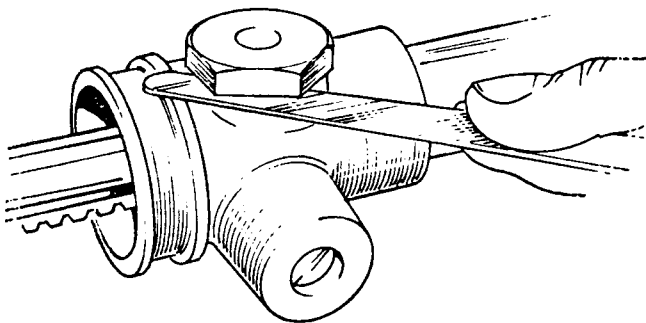

Fig. 14. MEASURING CAP NUT HEAD/  
PINION HOUSING CLEARANCE

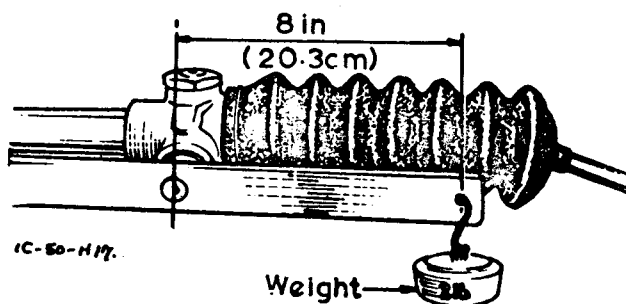

Fig. 15. ROTATING THE PINION

4. Fully tighten the coupling pinch bolt.
5. Replace the ball joint ends of the tie-rods into their respective steering arms and tighten nuts to the torque loading given in 'Technical Data'.
6. Replace front wheels.

H.7. - STEERING ARMS

To Remove

1. Remove the vertical link (see Section 'C').
2. Extract the lower two bolts securing the brake disc dust cover, the brake caliper mounting plate and the steering arm to the vertical link.

To Replace

1. Replacing the steering arms is a direct reversal of the removal procedure, but noting that they are handed. Ensure correct replacement. Tighten bolts to the torque loading given in 'Technical Data'.